

Management of Reactive Power Sharing for PV based Smart Microgrid System

Mahesh Kumar^{1*}, Prof. Siddharth Shukla²

M. Tech. Scholar, Department of Electrical and Electronics Engineering, TIT & Science, Bhopal¹
Assistant Professor, Department of Electrical and Electronics Engineering, TIT & Science, Bhopal²

Abstract: - Smart-grid proficiency stresses the complex networks of the electricity, it will bring together in future smart infrastructure for power system through dynamics among sources. This research proposes the vital operation of renewable energy sources (RES) like solar photovoltaic (PV), wind energy, fuel cell (battery) with an existing grid of AC and diesel generator as standby, in the interpretation of the cognitive and reliable process of power systems. These sources modeling and simulation is performed for optimal power flow based on power flow chart for demand-side management. The designed system fulfills realistic operation for the power system, based on fundamentals. The constraints are lively for synchronizing of voltage, frequency and waveform at the PCC for grid integration with RES. Also, these are beneficial for the switching of protective devices through remote monitoring and control. Finally, with these features, the developed system testing are conceded for linear, nonlinear and dynamic loading. These results are proximate to the specified tolerance at different universal morals.

Keywords:- Renewable Energy Sources (RES), Photovoltaic, Battery, Smart Grid, Microgrid

I. INTRODUCTION

Modern electric power markets worldwide have been experiencing dramatic changes due to the restructuring of the industry and over the years. Integration into the world economy has proven a powerful means for countries to promote economic growth, development, poverty reduction, as well as raised living standards all over the world. Trade has been an engine of growth for integration into the world economy. Since 1947, when the General Agreement on Tariffs and Trade (GATT) has created, the world trading system has benefited from trade liberalization [1].

Following the success of liberalization of various sectors of the economy, electricity markets underwent a similar transition. Vertically integrated utilities, which managed any electricity system needs generation, transport and distribution of electricity. Dis-integrating these utilities was unbundled, and competition in generation and distribution introduced [2, 3].

Hence, the development in electricity market has acquired substantial importance to incorporate seamless efficiency. As the world is determine to migrate from conventional fossil fuels to renewable energy, as a major part of green energy revolution. India is one of the

world's biggest users of coal, and the adoption of renewable energy such as solar photovoltaic (PV) power, wind power, etc. are on priority for the Government of India to meet India's rising fuel and renewable energy demand [4].

It's not a total replacement of conventional energy generation but considered to be an added source of energy. The necessary technology and up-gradation is necessary to be developed and implemented in a phased manner over the years, to meet the rapidly increasing demand for electricity, especially in the Indian context. The Electricity business is thus poised for robust value creation. Switching and its further automation will play a catalytic role in determining the future of this business activity. Using this thread, the area of research has been determined for the research work to be carried out [5].

Grid connected converters are required to transfer harvested green energy from wind and solar PV energy systems into the main grid. The importance of the single-phase grid connection for these sources should not be underestimated. It is one of the key components when it comes to stable and efficient power transfer from the solar PV or wind power or hybrid system into the grid. Not only grid-synchronization, also electromagnetic interference (EMI) problems, harmonic regulations and efficiency are important design issues that have to be solved [6].

II. SOLAR PV STAND-ALONE SYSTEM

A solar PV or solar power system is a power system intended to supply functional solar energy through PV. It consists of an arrangement of numerous components, including solar PV panels to absorb and transform sunlight into electricity, a solar PV inverter to change the electric current from DC to AC, as well as mounting, cabling, and other electrical accessories to set up a working system [7]. It may also use a solar PV tracking system to improve the system's overall performance and include an integrated battery solution, as prices for storage devices are expected to decline. Strictly speaking, a solar PV array only includes the collaborative of solar PV panels, the visible part of the solar PV system, and does not include all the other hardware, often summarized as a balance of the system. Furthermore, solar PV systems convert light directly into electricity and shouldn't be confused with other technologies, such as concentrated solar power or solar thermal, used for heating and cooling [8].

India receives solar energy equivalent to more than 5000 trillion kWh per year, which is far more than its total

annual consumption. The daily global radiation is around 5 kWh/ m² day with sunshine ranging between 2300 and 3200 hours per year in most regions of India. Though the energy density is low and the availability is not continuous, it has now become possible to harness this abundantly available energy very reliably for many purposes by converting it to usable heat or through the direct generation of electricity. The conversion systems are modular and can be appropriately used for decentralized applications. The typical Solar PV stand-alone system consists of a solar PV array and a battery connection as shown in Fig. 1. The array powers the load and charges the battery during the daytime. The battery powers the load after dark. The inverter converts the DC power of the array and the battery into 60 or 50 Hz power.

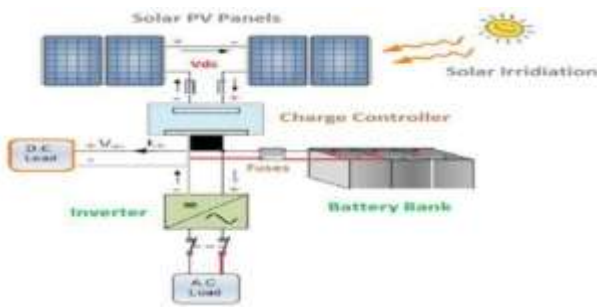

Fig.1: Solar PV stand-alone power system

III. CONTROL OF MICROGRID

The control strategies for microgrid depend on the mode of its operation. The aim of control technique should be to stabilize the operation of microgrid. When designing a controller, operation mode of MG plays a vital role. Therefore, after modelling the key aspect of the microgrid is control.

1. Control of Grid Connected

In grid connected mode, microgrid acts as a controllable load/source. It should not actively regulate the voltage at the point of common coupling (PCC). Its main function is to satisfy its load requirements with good citizen behavior towards main grid. The balance between generation and demand, control of the parameters of the system is taken care by the utility grid. The voltage and frequency reference of the microgrid is also set by the main grid. Therefore the main task of a DG unit is to control the output real power (P) and reactive power (Q).

2. Control Islanded Microgrid

In islanded mode, the reactive power sharing is highly dependent on impedance of power line. Due to the different distances among DERs interface converters (DICs), the equivalent transmission line impedance could be unequal [12]. *Pf* and *QV* droop characteristics are used in DER interface converters for power sharing operations. The *Pf* droop control provides an accurate real power sharing among the DIC's but the problem arises in *QV* droop control. Because of this unequal

impedance load sharing performance of *QV* control can be affected.

IV. SMART GRID

The present demand side management strategies used in traditional energy management systems employs scheme specific techniques and algorithms and in addition to it the existing approaches handle only a limited number of controllable loads of limited types. Demand side management strategies are based on load shifting technique for DSM of future smart grids with a large number of devices of several types.

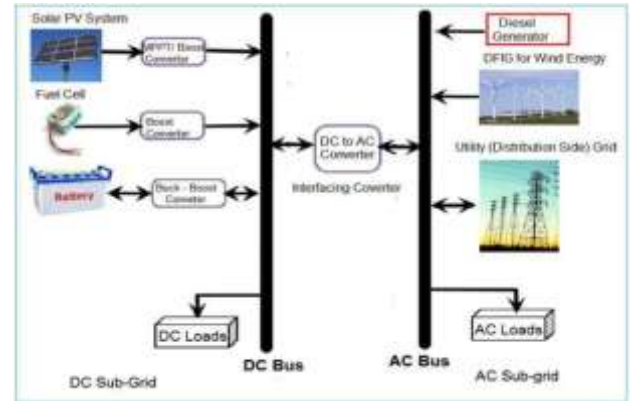

Fig.2: RES for grid integration

The day-ahead load shifting technique proposed in this paper is mathematically formulated as a minimization problem.

A heuristic-based evolutionary algorithm that easily acclimatizes was developed for solving this minimization problem and simulations were carried out on a smart grid which contains a variety of loads in three service areas, one with residential customers, another with commercial customers, and the third one with industrial customers. The simulation results show that the DSM strategy achieves substantial savings, though reducing the peak load demand of the smart grid.

The advanced measurement system based on synchro phasors was also implemented using DAQs real-time synchronous data. The developed system features a wide variety of competences such as online system parameters calculation and online voltage stability monitoring. These are implemented as an experimental case to improve WAM. Furthermore, the protection system was designed inside of the real-time software environment to monitor the real-time wide area data, and make a comprehensive and reliable coordination for the entire system and ideas related to the communication of a dc microgrid involving sustainable energy sources with the main ac grid have been also implemented and presented. The implemented system is obvious and possible in any research laboratory and for real-time real-world smart grid systems.

Various literature and publications on the topic of the thesis are discussed in the preceding section to recognize and describe the possibility of the research work. In this

section scope, aim and objectives of the research involvement are defined.

The first part of the literature shows that the setting or spread of the grid interconnection with individual or multiple RES has certain challenges like:

- Providing the screening applications for power system parameters
- The power flow solution
- Multi-phase analysis
- Circuit model size
- Harmonics
- Determining the value of DG
- Modeling sub-transmission
- Assessing distribution reliability
- Loss analysis
- Protective device coordination

V. METHODOLOGY AND RESULTS

The RES with modern authenticity is imparting for grid integration as a portion of a smart grid. In this chapter, expertise for RES like solar PV, wind energy, along with storage battery (fuel cell) with advanced features of grid integration is applied for monitoring and control of power system parameters. The system behavior is controlled by DSP as per the requirement of load and in which energy is supplied through RES with grid interconnection.

Technologies have been developed to harness this energy to fulfill this demand. These sources were individually used to supply the load. Each source has its own set up to harness energy convert into electricity and supply to the load. But the drawback of such a method is that they are not reliable and load get often interrupted which causes varieties of problems. To overcome the discussed difficulties the DSP controller has been adopted to take into consideration various energy sources. These can generate and supply an uninterrupted approach through a designed three-phase inverter. The algorithm has been developed for transit between the energy sources as per their availability such as harness the maximum amount of energy generated from RES.

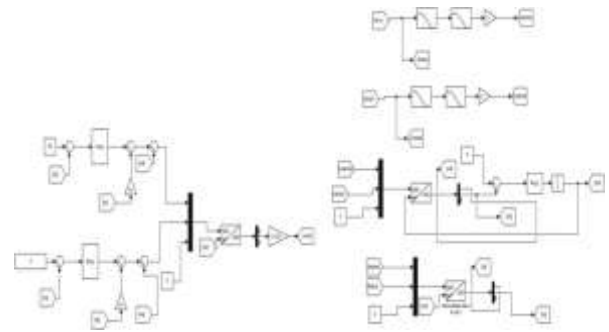
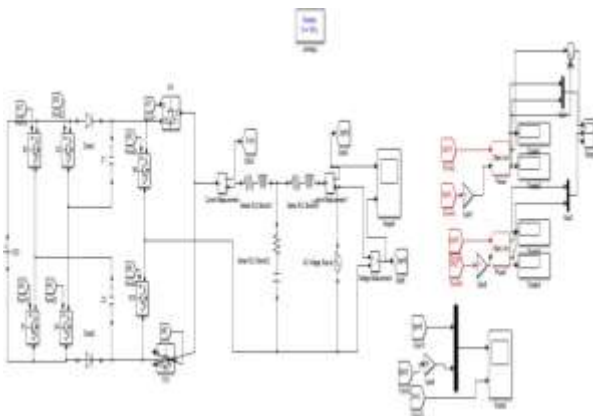

Fig.3: Simulation Model of Proposed Methodology

Power electronic interfacing based strategies for conversion of DC to AC for grid integration of RES causes voltage/current harmonic distortions in the power grid. This section presents a simulation for harmonic current profiles for three-phase inverters of these interfacing for individual source.

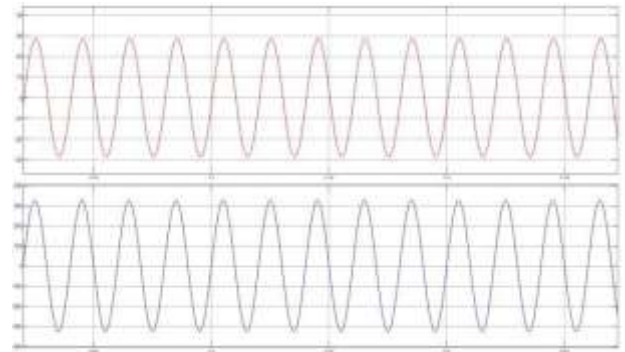

Fig. 4: Grid current and grid voltage are in same phase

In this context, harmonic mitigation for RES while grid integration. The system is planned for 10 kW capacities for loads with the switching of the L-C circuit by programming in the DSP. The action for switching the L-C circuit is performed by sending voltage and current status through hall-effect sensors. The harmonics are mitigated for the THD level.



Fig. 5: Unity Power factor at the grid side

Power quality describes the importance of the issues found in any electrical system; these issues are depended on the perspective of the end-user network. But it is repeatedly detected that there is a deviation in sinusoidal voltage and current waveforms. This distortion is

nothing but the harmonics and the reason for the concern at different stages in electrical power systems. This harmonic distortion affects different electric machines, telecommunication systems, etc. Non-linear loads keep on adding to harmonics and the most widely used non-linear loads are power convertors, speed control of motors, transportation systems, and domestic appliances. After a certain level, reactive impedance of the system form tank circuit with the inductive reactance of the system at the resonant frequency which gives rise to the large currents.

VI. CONCLUSION

The smart grid distribution system developed through power electronics will support to utilize RES and operate in an automated way. The whole configures both communication network and power line network has successfully achieved in session to work in the mode of master-slave towards the fulfillment of dynamic loading on demand-side management.

Hence it is concluded that the proposed designed and developed pilot model shows consistency in the results and having the evidence of successful integration of RES into the grid thus called Smart Grid. It is expected that when a large scale RES integrates is future of the world large scale development of this pilot model will be, an integrated part for all smart grid operation purposes. The simulation results shows that the standard deviation of the utilization factors of the inverters with the proposed approach is significantly less than that achieved with conventional Proportional Nominal Apparent Power Sharing (PNAPS) method.

REFERENCES

- [1] Farshid Kamrani, Sajjad Fattaheian-Dehkordi, Ali Abbaspour1, Mahmud Fotuhi-Firuzabad and Matti Lehtonen, "Investigating the Impacts of Microgrids and Gas Grid Interconnection on Power Grid Flexibility", Smart Grid Conference (SGC), IEEE 2019.
- [2] J. H. R. Enslin, "The role of power electronics and storage to increase penetration levels of renewable power," Power and Energy Society General Meeting - Conversion and Delivery of Electrical Energy in the 21st Century, IEEE Press, pp. 1-2, July (2008) DOI: 10.1109/PES.2008.4596958
- [3] B. Parida, S. Iniyar, and R. Goic, "A review of solar photovoltaic technologies" Renewable and Sustainable Energy Review, 15, 1625-1636 (2011) DOI: 10.1016/j.rser.2010.11.032
- [4] S. Kurtz, "Opportunities and challenges for development of a mature concentrating photovoltaic power industry," Technical Report NREL/TP-520-43208, Revised November (2009)
- [5] J. Karp, "Concentrating solar power: progress and trends," Jacobs School of Engineering, University of California San Diego, Triton SPIE/OSA, February 12 (2009)
- [6] L. Micheli, N. Sarmah, X. Luo, K. S. Reddy, and T. K. Mallick, "Opportunities and challenges in micro- and nano-technologies for concentrating photovoltaic cooling: A review" Renewable and Sustainable Energy Reviews, 20, 595-610 (2013) DOI: 10.1016/j.rser.2012.11.051
- [7] H. Zhang and L. L. Lai, "Research on wind and solar penetration in a 9- bus network" Proc. IEEE Power and Energy Society General Meeting, IEEE Press, pp. 1-6, July (2012) DOI: 10.1109/PESGM.2012.6345218
- [8] P. Komor, "Wind and solar electricity: challenges and opportunities," University of Colorado at Boulder, Pew Center on Global Climate Change, June (2009)
- [9] B. S. Borowy and Z. M. Salameh, "Methodology for optimally sizing the combination of a battery bank and PV array in a Wind/PV hybrid system" IEEE Transactions on Energy Conversion, 11, 367-375 (1996) DOI: 10.1109/60.507648
- [10] S. H. Karaki, I. R. B. Chedid, and R. Ramadan, "Probabilistic performance assessment of autonomous solar-wind energy conversion systems" IEEE Transactions on Energy Conversion, 14, 766-772 (1999) DOI: 10.1109/60.790949
- [11] R. Luna-Rubio, M. Trejo-Perea, D. Vargas-Vázquez, and G. J. Ríos-Moreno, "Optimal sizing of renewable hybrids energy systems: A review of methodologies" Solar Energy, 86, 1077-1088 (2012) DOI: 10.1016/j.solener.2011.10.016
- [12] [21] P. G. Arul, V. K. Ramachandramurthy, and R. K. Rajkumar, "Control strategies for a hybrid renewable energy system: A review" Renewable and Sustainable Energy Reviews, 42, 597-608 (2015) DOI: 10.1016/j.rser.2014.10.062
- [13] B. Bhandari, K. T. Lee, G. Y. Lee, Y. M. Cho, and S. H. Ahn, "Optimization of hybrid renewable energy power systems: A review" International Journal of Precision Engineering and Manufacturing - Green Technology, 2, 99-112 (2015) DOI: 10.1007/s40684-015-0013-z
- [14] M. Esteban, Q. Zhang, A. Utama, T. Tezuka, and K. N. Ishihara, "Methodology to estimate the output of a dual solar-wind renewable energy system in Japan" Energy Policy, 38, 7793-7802 (2010) DOI: 10.1016/j.enpol.2010.08.039
- [15] H. H. Chen, H. Y. Kang, and A. H. I. Lee, "Strategic selection of suitable projects for hybrid solar-wind power generation systems" Renewable and Sustainable Energy Reviews, 14, 413-421 (2010) DOI: 10.1016/j.rser.2009.08.004
- [16] S. Bhattacharjee and S. Acharya, "PV-wind hybrid power option for a low wind topography" Energy Conversion and Management, 89, 942-954 (2015) DOI: 10.1016/j.enconman.2014.10.065.