



Development of an Automated Smart Parking System Using Embedded Sensors

¹Himanshu Raj, ²Golu Kumar, ³Himanshu Kumar Rai, ⁴Harsh Raj

Department of ECE, Lakshmi Narain College of Technology, Bhopal (M.P), India

ABSTRACT

Smart Car Parking systems are innovative solutions designed to address the challenges faced by drivers when searching for parking spaces, especially in busy urban areas during peak hours. These systems utilize IoT technology deployed on-site to monitor and indicate the availability status of individual parking spaces. Additionally, a mobile application is provided to enable users to conveniently check the availability of parking spaces and easily locate vacant slots. By implementing a Smart Parking system, drivers can save valuable time and avoid the frustrations associated with the daunting task of finding suitable parking spots. Moreover, these systems play a crucial role in alleviating traffic congestion and reducing air pollution in densely populated urban areas. However, it is important to consider the costs associated with the installation of Smart Parking systems. The implementation process requires the use of camera sensors and costly infrastructure such as line or cabling. The core circuitry involves the integration of NodeMCU, which is connected to infrared (IR) sensors. These IR sensors effectively detect the presence of a parked car and transmit a signal to the NodeMCU. Subsequently, the mobile application is notified, and the corresponding parking slot is accurately displayed as "occupied." In conclusion, the adoption of Smart Parking systems offers numerous benefits, including time savings, reduced frustration, traffic alleviation, and environmental advantages. Although there are cost considerations involved, the implementation of these systems has the potential to greatly enhance the overall parking experience and contribute to the development of smarter and more efficient cities.

Keywords: Smart Parking System, Internet of Things (IoT), NodeMCU, Infrared (IR) Sensors, Mobile Application, Real-Time Monitoring, Occupancy Status, Traffic Congestion, Urban Infrastructure, Cost-Effective Automation

1. INTRODUCTION

Urban congestion and the inefficient management of parking spaces represent significant challenges in modern cities, leading to increased traffic, wasted time, and higher fuel consumption. In environments where parking resources are critically limited, drivers often struggle to find available spots manually, highlighting the urgent need for automated and efficient parking management solutions. The Smart Car Parking System addresses this challenge by offering an automated, cost-effective, and easy-to-maintain prototype that seamlessly manages vehicle entry and tracks space availability in real-time.

This innovative system is engineered to enhance parking efficiency and improve user convenience through the integration of cutting-edge microcontroller technology. The device is equipped with Infrared (IR) sensors positioned strategically at the entry and exit points, as



well as at individual parking slots, to detect the presence of vehicles. Upon detecting a car at the entrance, the system instantly processes the data and signals a Servo Motor, which acts as an automated barrier gate, rotating precisely to allow or restrict entry.

Alongside automated gate control, the system incorporates a Liquid Crystal Display (LCD) to provide real-time visual feedback to arriving drivers, displaying the exact number of available parking slots or indicating a "Parking Full" status before entry.

From a technical standpoint, the system utilizes Embedded C/C++ language for programming within the Arduino IDE environment. An Arduino UNO (based on the ATmega328P microcontroller) serves as the central processing unit, managing the input signals from the IR sensors and coordinates the output responses. The Servo Motor provides physical automation for the barrier, while the I2C/Standard LCD module handles the dynamic data display. This combination of low-power components ensures a highly responsive, scalable, and energy-efficient solution for modern smart-city infrastructure.

2. LITERATURE REVIEW

In the field of smart parking management, various related works have been explored to tackle urban congestion and optimize space utilization. Existing academic and industrial systems utilize a wide range of sensors, cloud technologies, and user interfaces to gather and present real-time parking data. However, many of these advanced architectures—such as camera-based license plate recognition (LPR) or extensive computer vision models—require costly private infrastructure, high computational power, and continuous internet connectivity, making them difficult to deploy in budget-constrained or decentralized environments.

Several foundational approaches focus on automated access control and visual feedback at the entry points. For instance, researchers have developed frameworks where Infrared (IR) sensors are deployed at entry and exit gates to regulate vehicle flow. In parallel, entry barriers are often automated using electronic gates driven by stepper or DC motors. To guide incoming drivers, many traditional systems rely on remote mobile applications connected to central cloud databases, which update slot availability over the internet. While effective, these solutions introduce latency and fail if the local network or internet server experiences downtime.

To address the limitations of high cost, complex infrastructure, and dependency on external servers, localized embedded solutions have gained significant traction. Specifically, microfluidic and micro-controller-based systems offer a direct, standalone approach to parking automation. A notable configuration in recent literature involves the integration of low-cost proximity sensors with physical barriers to create an autonomous zoning system. By relying on immediate hardware-level processing rather than remote cloud computations, these localized systems drastically reduce response times for barrier operations and display updates.

Our proposed system aligns with this cost-effective, localized paradigm by implementing an automated, high-efficiency architecture using an Arduino UNO, IR sensors, an LCD module,



and a servo motor. Instead of relying on expensive camera feeds or unstable network servers, our design utilizes strategically positioned IR sensors to instantly detect vehicle presence at the gate and individual slots.

3. OVERVIEW

In today's urban environments, finding an available parking space has become a common challenge, leading to increased congestion and frustration for drivers. To address this issue, I propose the development of a Smart Car Parking System that leverages cost-effective technology to automate space management and improve efficiency. By utilizing an Arduino microcontroller and advanced IR sensors capable of detecting vehicle presence, this system aims to monitor parking slot occupancy in real-time. These sensors will instantly identify free spaces and automatically control an entry barrier driven by a servo motor. To enhance user convenience, a localized LCD module will be implemented at the entrance to gather and display the live occupancy data, assisting drivers in locating vacant parking slots efficiently before entering.

4. MOTIVATION

- 1). **Automated Entry Management:** Users experience seamless and automated access control at the entrance. The real-time processing of IR sensors combined with the swift action of the servo motor barrier eliminates the need for manual gate operations.
- 2). **Reduced Traffic Congestion:** With an LCD display at the entrance showing live slot availability, drivers don't have to idle or wander around looking for open spots, which directly reduces traffic accumulation at the entry points.
- 3). **Cost-Effective Deployment:** Unlike high-end systems that require expensive cameras, internet servers, or cloud infrastructure, this standalone Arduino-based model offers a highly affordable and energy-efficient solution suitable for local environments.
- 4). **Improved User Experience:** The system integrates immediate visual feedback right before entry. Drivers are instantly informed about the occupancy status and vacant slots on the LCD module, enhancing the overall convenience of parking without requiring a smartphone.
- 5). **Enhanced Space Utilization:** By utilizing individual IR sensors for each designated parking slot, the system precisely tracks empty spaces. This allows parking lot owners to maximize their available area and systematically guide vehicles to the right spots.
- 6). **Simplified On-Site Management:** Returning users can easily bypass long manual queues and administrative delays because the system relies on immediate, hardware-level slot detection. This standalone operation removes the need for complex mobile configurations or continuous manual assistance, allowing for a smooth and straightforward flow of vehicles.
- 7). **Increased Safety and Order:** Real-time data provided by the strategically placed IR sensors aids parking lot operators in maintaining order, ensuring vehicles park precisely within designated slots and preventing blocking violations. Additionally, by eliminating erratic



driving and sudden stops from drivers searching for spaces, the automated layout significantly minimizes minor on-site accidents and fender-benders.

8). Scalable Operational Insights: The local microcontroller architecture serves as a foundational platform that can be adapted over time to track peak hours and occupancy trends. These physical data patterns allow lot owners to better understand high-traffic intervals and optimize room allocation, facilitating future expansion or localized adjustments without heavy structural modifications.

9). Reduced Management Costs: The total automation of the entry barrier using a servo motor, combined with self-updating LCD status displays, drastically decreases manual supervision requirements. This reduction in daily physical monitoring results in substantial long-term cost savings for management by minimizing labor dependency and optimizing resource efficiency.

5. GOALS AND OBJECTIVES

The smart car parking system is a comprehensive solution designed to identify the closest available parking area. Its primary objective is to address the challenges associated with parking by minimizing the time spent searching for parking spaces and eliminating unnecessary vehicle travel.

6. MATERIALS AND METHODS

Problem

One common issue faced by drivers is the time-consuming process of finding suitable parking spaces. To address this problem, an automated car parking system has been developed. The objective is to provide assistive technology that offers parking information to registered customers through smartphone applications. By registering and booking in advance, users can receive details about available parking spaces, their destination, and estimated arrival time.

Scope

The proposed project aims to eliminate the need for human intervention in parking management, thus reducing labor requirements. The system automates the process of detecting vehicles and closing the gates by employing sensors and alarms. The project's benefits include increased efficiency and improved utilization of parking areas. Moreover, the system's versatility allows for potential applications in various domains, such as railway stations, apartment complexes, and military installations.

Project Goals

The primary goal of the smart car parking system is to identify the nearest available parking zone. Doing so, aims to address the parking problem by minimizing the time spent searching for parking spaces and eliminating unnecessary vehicle travel.

System Design and Implementation Components Used:



1. **IR Sensors:** Infrared sensors are electronic devices used to detect the presence of objects. These sensors emit infrared light and analyze its reflection. If no light is reflected back to the receiver, it indicates the absence of an object, whereas the detection of reflected light signifies the presence of an object. In the context of this smart car parking system, IR sensors are strategically employed at the entry gate and individual slots to determine vehicle presence, transmitting this data instantly to the central microcontroller.
2. **Arduino UNO:** The Arduino UNO is an open-source development board based on the ATmega328P microcontroller, widely used for embedded prototyping. It features a set of digital and analog input/output pins that interface with various expansion boards and circuits. In this project, the Arduino UNO serves as the central processing unit, responsible for reading real-time inputs from the IR sensors, calculating slot availability, controlling the servo motor barrier, and updating the local LCD screen.
3. **Volt DC Power Supply / Arduino USB Supply:** A stable power source is required to drive the microcontroller and its peripherals. The system utilizes a 5V DC power supply (regulated via a standard adapter or power bank) or a direct USB connection to distribute steady current to the power-hungry components like the servo motor and the LCD backlight.
4. **Connecting Wires and Breadboard:** Standard jumper wires (Male-to-Male, Male-to-Female) and a breadboard are utilized to establish secure electrical connections between the Arduino UNO, the distributed IR sensors, the LCD module, and the servo motor, ensuring clean signal transmission across the hardware setup.

By combining these components, the automated car parking system achieves its objectives of providing real-time parking information and automating gate operations. The integration of IR sensors and the NodeMCU controller enables efficient management and utilization of parking spaces, leading to a more streamlined parking experience for users.

E. Working

The operational process of the automated car parking system involves the utilization of IR sensors placed at the entry gate and in front of each individual parking slot, facing the direction of the vehicles. These sensors are responsible for detecting the presence or absence of a car in front of them. Through the physical connection between the IR sensors and the Arduino UNO, the collected data regarding the occupancy of each parking slot and the entry point is transmitted directly to the Arduino microcontroller.

Using the received information, the Arduino UNO controller then processes the slot counts in real-time and communicates the current parking availability status to the driver via a localized LCD module installed at the entrance, while simultaneously operating a servo motor to open or close the barrier gate. When a driver enters the parking area, they can conveniently view the LCD screen to check the number of vacant spots in real time. With this knowledge, the driver can proceed through the automated servo barrier and park their vehicle in an unoccupied slot, optimizing the parking space utilization.

To summarize, the IR sensors continuously monitor the presence of vehicles at the gate and within each slot, relaying the data to the Arduino UNO. The Arduino, in turn, communicates this information to the driver through the local LCD display and controls the physical entry using the servo motor, enabling them to locate and utilize the available parking slots efficiently without requiring external applications.

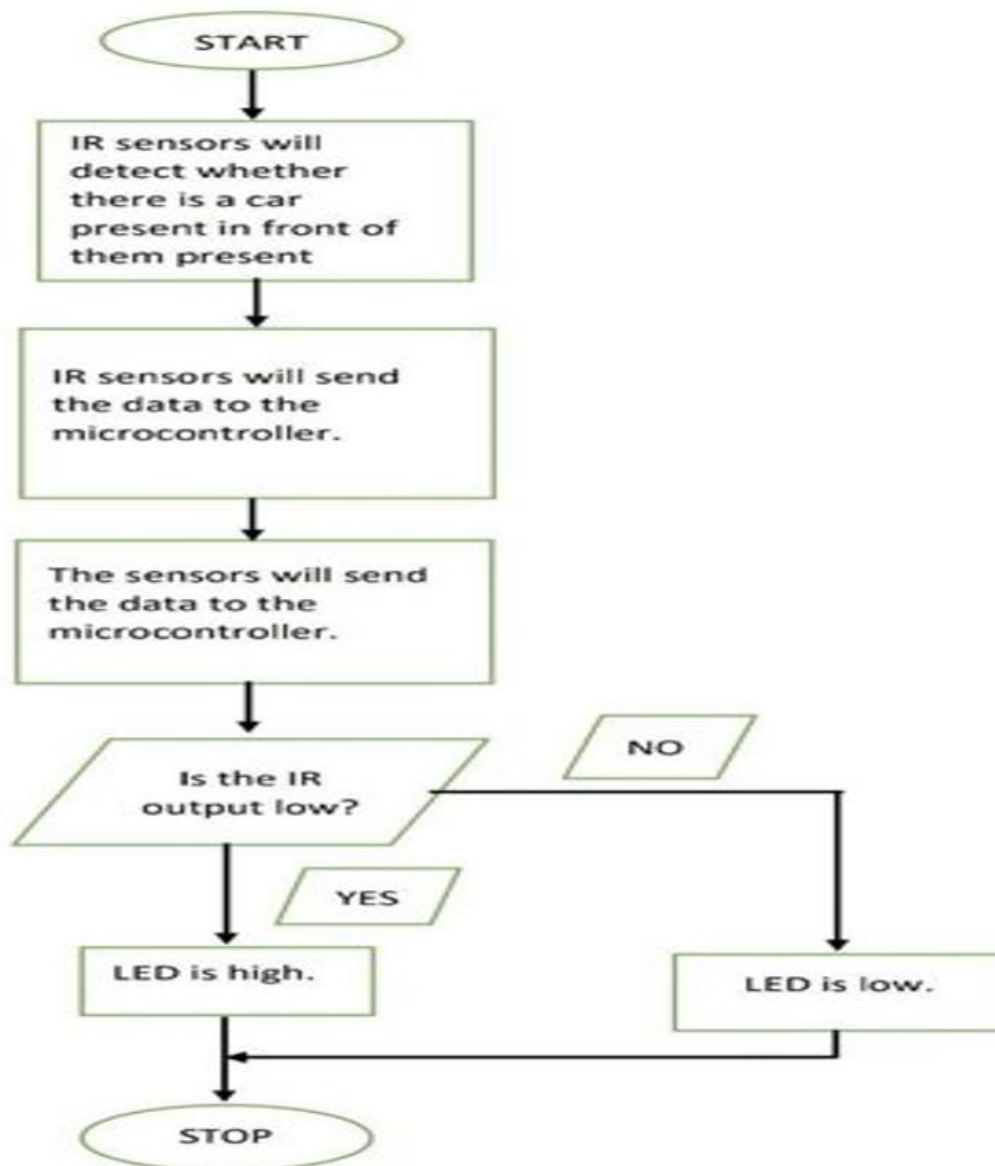

Fig 1. Flowchart of working of the circuit

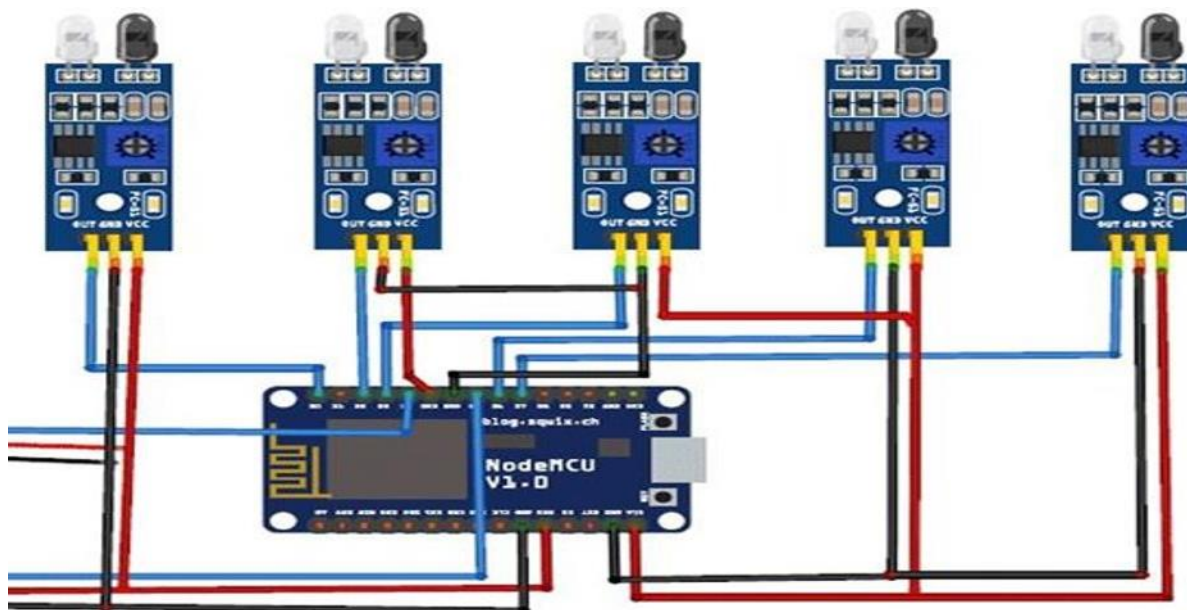

Fig 2. Circuit Diagram

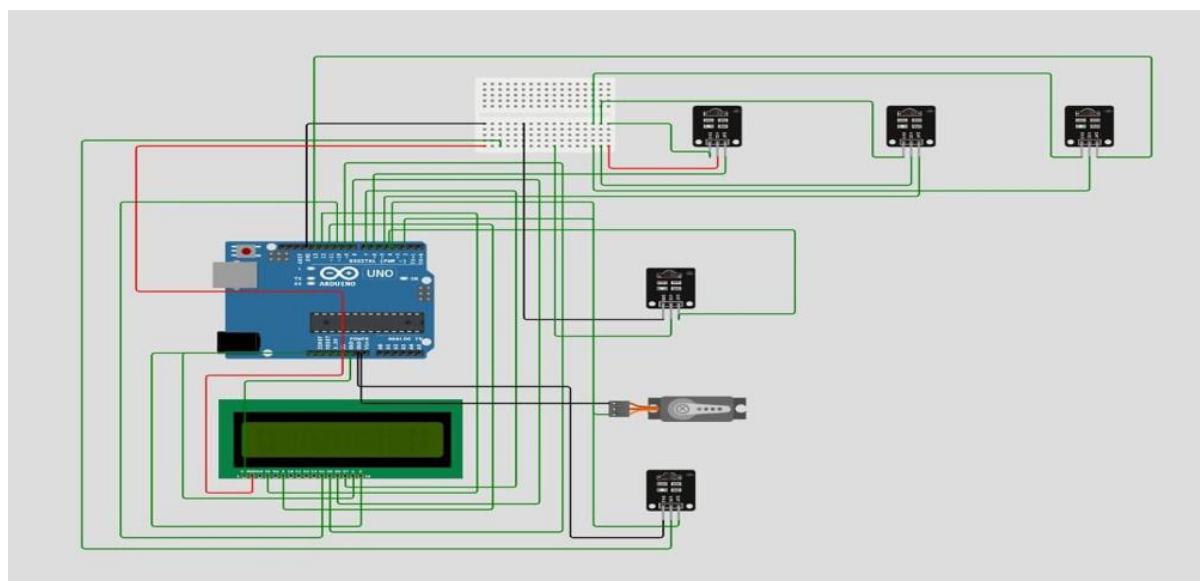

Fig 3. Connections

7. RESULT AND DISCUSSION

The demand for smart parking systems is rapidly increasing due to their ability to provide real-time information about available parking spaces. However, many current automated architectures rely on complex, high-maintenance components or computer-vision setups that lack cost-efficiency and require high processing power. One existing approach uses a vision-based monitoring system that counts incoming and outgoing cars to estimate available parking slots, which can be computationally heavy and prone to ambient lighting errors. Another system relies on expensive wireless sensor networks or cloud architectures.

The objective of this project is to establish a direct connection between physical parking areas and an efficient, standalone hardware infrastructure, aiming to reduce the time spent searching for parking and provide a highly cost-effective solution for users. By integrating responsive IR sensors at individual slots and the entrance, the system seeks to automate access control via a precise servo motor barrier and provide immediate, localized status updates. This localized feedback loop eliminates the need for expensive network dependencies while addressing efficiency bottlenecks and minimizing the fuel consumption associated with searching for parking spaces.

In essence, this work emphasizes the need to enhance entry-level parking systems by leveraging accessible embedded technology to improve operational speed, reduce vehicle emissions, and enhance the overall driver experience through immediate visual feedback.



Fig 4. Working Model



Fig 5. Working Model

8. CODE AND CODE OUTPUT



```
#define BLYNK_TEMPLATE_ID "TMPLxxxxxx" #define BLYNK_TEMPLATE_NAME  
"Smart Parking System" #define BLYNK_AUTH_TOKEN "Your_Auth-Token_Here"  
  
#include <ESP8266WiFi.h> #include <BlynkSimpleEsp8266.h>  
  
char auth[] = BLYNK_AUTH_TOKEN; char ssid[] = "Your_WiFi_SSID"; char pass[] =  
"Your_WiFi_Password";  
  
#define COLOR_GREEN "#00FF00" #define COLOR_RED "#FF0000"  
  
void setup() { Serial.begin(115200); Blynk.begin(auth, ssid, pass);  
  
pinMode(16, INPUT); pinMode(5, INPUT); pinMode(4, INPUT); pinMode(0, INPUT);  
pinMode(2, INPUT); }  
  
void loop() { Blynk.run();  
  
int val0 = digitalRead(16); Blynk.virtualWrite(V0, 255); if (val0 == HIGH) {  
Blynk.setProperty(V0, "color", COLOR_GREEN); } else { Blynk.setProperty(V0, "color",  
COLOR_RED); }  
  
int val1 = digitalRead(5); Blynk.virtualWrite(V1, 255); if (val1 == HIGH) {  
Blynk.setProperty(V1, "color", COLOR_GREEN); } else { Blynk.setProperty(V1, "color",  
COLOR_RED); }  
  
int val2 = digitalRead(4); Blynk.virtualWrite(V2, 255); if (val2 == HIGH) {  
Blynk.setProperty(V2, "color", COLOR_GREEN); } else { Blynk.setProperty(V2, "color",  
COLOR_RED); }  
  
int val3 = digitalRead(0); Blynk.virtualWrite(V3, 255); if (val3 == HIGH) {  
Blynk.setProperty(V3, "color", COLOR_GREEN); } else { Blynk.setProperty(V3, "color",  
COLOR_RED); }  
  
int val4 = digitalRead(2); Blynk.virtualWrite(V4, 255); if (val4 == HIGH) {  
Blynk.setProperty(V4, "color", COLOR_GREEN); } else { Blynk.setProperty(V4, "color",  
COLOR_RED); }  
  
delay(500); }
```

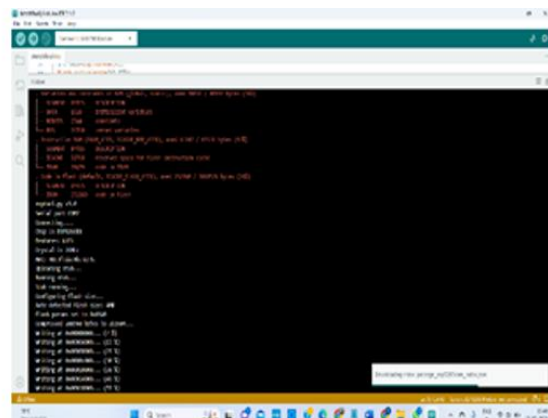
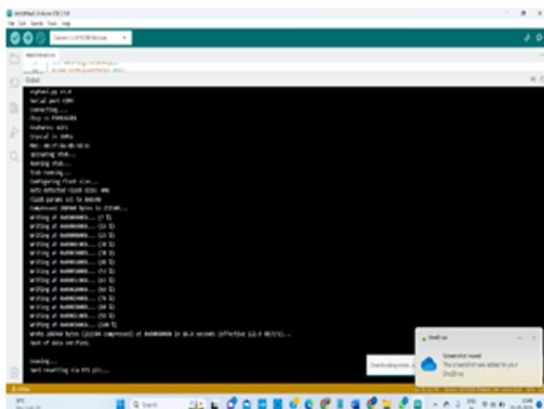

Fig 6. Screenshots of Arduino Environment

9. ADVANTAGES

1. **Cost Savings:** By driving more efficiently and locating parking spaces quickly, users can save money on fuel expenses, resulting in reduced petrol costs.
2. **Optimized Parking:** The smart parking system enables users to find the most suitable parking spot, saving time, resources, and effort.
3. **Reduced Fuel Consumption:** Directing drivers to available parking spaces minimizes unnecessary driving in search of vacant spots, leading to reduced fuel wastage and lower vehicle emissions.
4. **Stress Reduction:** The smart parking system alleviates the stress of drivers by simplifying the process of finding a parking space.
5. **Reduced Traffic Congestion:** With fewer drivers searching for parking, the smart parking system contributes to a decrease in traffic on the streets.

10. DISADVANTAGES

1. **High Initial Setup Cost:** Procuring hardware components like multiple IR sensors, an Arduino UNO, a servo motor, and an LCD screen increase the initial prototype and installation costs compared to traditional manual parking layouts.
2. **Limited Range and Line-of-Sight Dependency:** IR sensors rely strictly on a direct line of sight. Environmental factors such as dust, heavy rain, direct sunlight, or dirt accumulating on the sensor lens can block the infrared light, leading to false occupancy triggers or missed vehicle detection.
3. **Lack of Remote Monitoring:** Since this specific architecture utilizes a local LCD module at the entrance rather than a cloud-connected server or a mobile application, drivers cannot check slot availability from a remote distance before arriving at the venue.
4. **Component Wear and Tear:** The continuous physical operation of the servo motor to lift and lower the gate barrier introduces mechanical friction, which can lead to wear and tear over time, requiring regular maintenance or replacement.
5. **Power Dependency:** The entire system relies heavily on a stable 5V power supply. Any sudden power outage or voltage fluctuation can shut down the microcontroller, causing the automated gate barrier to malfunction and disrupting the entry or exit flow.

11. FUTURE WORK

The transition of modern urban centers into smart cities is driven by IoT and embedded automation, with smart parking serving as a crucial pillar. While the current prototype successfully demonstrates localized real-time slot tracking using an Arduino UNO, IR sensors, a servo motor, and an LCD module, its future development lies in global



connectivity and enhanced security. Future updates will replace the local physical display with a dedicated mobile application integrated via cloud frameworks like Blynk, enabling drivers to check slot availability remotely. Furthermore, the architecture can expand to incorporate advance slot reservations paired with digital payment gateways. To enhance security, integrating automated license plate recognition (ALPR) via camera modules can eliminate physical ticketing and prevent vehicle theft. Finally, syncing the system with GPS navigation can provide turn-by-turn routing inside multi-level parking structures, while adding automated EV charging docks to individual slots will ensure the design remains scalable and fully aligned with next-generation smart-city ecosystems.

12. CONCLUSION

The implementation of a smart parking system has become crucial in the development of smart cities. This presentation emphasizes the integration of a comprehensive solution for efficient parking management. The proposed system leverages the power of the Internet of Things (IoT) to accurately detect available parking spaces. Additionally, a user-friendly and visually appealing Android application was developed to enhance the overall experience. The system offers numerous advantages, such as time-saving capabilities, reduced pollution, and minimized fuel consumption.

ACKNOWLEDGEMENT

The team members would like to acknowledge the efforts of our project guide, Dr. Monika Kapoor, whose continuous guidance and encouragement have propelled us to realize our ideas. We would also like to thank all of our friends who have given valuable inputs throughout the duration of this project. Furthermore, we express our sincere gratitude to our college, Lakshmi Narain College of Technology, for providing us with the necessary infrastructure and resources to successfully execute this project.

REFERENCES

1. C. Patel, M. Swami, et al., "Smart Parking System Using Sensors," International Journal of Engineering Research and Applications (IJERA), ISSN: 2250-3153.
2. "Design and Implementation of Car Parking Using FPGA," International Journal of VLSI Design & Communication Systems (VLSICS), vol. 4, no. 3, June 2013.
3. A. Ahad et al., "Development of an Automated Parking Management System," World Journal of Engineering and Technology, vol. 4, pp. 160-167, 2016.
4. DirectPark Systems, "Automated Parking Solutions and Infrastructure," Available: <http://www.directpark.de>.
5. NXP Semiconductors, "Microcontrollers and Embedded Processing Platforms," Available: <http://www.nxp.com>.