



## **Smart Blind Stick**

**<sup>1</sup>Hritik Raj, <sup>2</sup>Mohammad Aadil, <sup>3</sup>Om Prakash, <sup>4</sup>Nitish Gadge**

<sup>1/2/3/4</sup>Dept. of Electronics & Communication Engineering Lakshmi Narain College of  
Technology  
Bhopal, India

### **ABSTRACT**

Visual impairment, whether caused by physiological or neurological conditions, significantly affects an individual's ability to function independently in daily life, as it can range from partial to complete and temporary to permanent loss of sight. With the growing desire among visually impaired individuals to lead self-sufficient lives, the Smart Blind Stick has emerged as a groundbreaking assistive technology designed to address the everyday challenges they encounter. This intelligent device combines multiple functional components, including three ultrasonic sensors for obstacle detection, a soil moisture sensor, a panic button, a navigation switch, and a Bluetooth module, all powered by an Arduino UNO microcontroller. By continuously scanning the surrounding environment, the ultrasonic sensors alert the user to nearby obstacles, while the moisture detection system, positioned at the base of the stick, evaluates the condition of the ground surface ahead, enabling the user to make informed decisions about whether it is safe to proceed. Together, these integrated features empower visually impaired individuals to navigate their surroundings with greater confidence, safety, and independence, reducing their reliance on others for assistance during everyday movement.

**Keywords:** Smart blind stick, Arduino uno, ultra sonic sensor, infrared sensor, soil moisture detector, buzzer, microphone, GPS, android app

### **1. INTRODUCTION**

Visual impairment represents one of the most widespread disabilities affecting millions of people across the world, with nearly 90% of those living with vision loss residing in developing nations where access to assistive resources remains critically limited. These individuals often struggle to perform basic daily activities independently, highlighting the urgent need for affordable and effective assistive solutions. The Smart Blind Stick addresses this challenge by offering a device that seamlessly combines both automated and manual operation, making it cost-effective, easy to maintain, and comfortable for long-term use by visually challenged individuals.

This innovative assistive tool is engineered to enhance navigation and improve obstacle awareness through the integration of cutting-edge technology. The device is equipped with three ultrasonic sensors that continuously emit ultrasonic waves to identify barriers in the user's path, instantly relaying the detected information to the user through an audio output device. Alongside obstacle detection, the stick incorporates a Global Positioning System to determine the user's precise location using GPS coordinates, enabling smarter and safer navigation through unfamiliar environments.



From a technical standpoint, the device utilizes embedded C language for programming, an Atmega328 low-power CMOS microcontroller for processing, GSM technology to facilitate voice-based communication, and Bluetooth connectivity to wirelessly link the microphone to the device. A soil moisture sensor, panic switch, navigation switch, and Arduino UNO further enhance the overall functionality of the system. and Arduino UNO further enhance the overall functionality of the system.

## 2. COMPARATIVE TECHNOLOGIES

### A. *Smart blind walking stick using PIC16F676*

The Smart Blind Stick is a remarkable assistive innovation developed to significantly improve the navigation experience for visually impaired individuals by combining advanced sensing technology with intelligent processing capabilities. At the core of the device, ultrasonic sensors work in conjunction with an RF module to continuously scan the surrounding environment, detecting nearby obstacles by emitting and receiving ultrasonic waves.

Once an obstacle is identified, the collected data is transmitted to the PIC16F676 microcontroller, which processes the information and calculates the proximity of the detected object before determining the appropriate response. When an obstacle is deemed close enough to pose a risk, the microcontroller activates a motor connected to the stick, providing the user with a physical alert, while objects beyond a safe distance trigger no unnecessary response, ensuring a smooth walking experience.

Additionally, the device is equipped with a wireless RF-based remote-control system that serves as a locating feature, allowing the visually impaired user to find their stick whenever it is misplaced simply by pressing a button on the remote, which triggers an audible buzzer on the device. The overall hardware architecture of the system includes ultrasonic sensors, a motor interface for feedback, programmable control buttons, and a battery-powered circuit, all working together in a compact and efficient manner. Furthermore, the device has been thoughtfully designed in a detachable and portable form factor, allowing it to be conveniently attached to any standard walking stick without any conditional restrictions, making it a highly practical and adaptable solution for everyday use by the visually impaired.

### B. *Smart Microcontroller Based Blind Guidance System*

The proposed system is built around three strategically positioned infrared sensors, namely a front IR sensor, a right IR sensor, and a left IR sensor, all of which serve as the primary sensory components responsible for gathering environmental data and effectively acting as artificial eyes for visually impaired users. The signals captured by these three sensors are fed as inputs into the Analog-to-Digital Converter of the PIC16F877A microcontroller, which processes the incoming data to identify any triggered response and subsequently generates both vibration and sound alerts to notify the user of potential hazards. Unlike conventional computing systems, the PIC microcontroller operates directly from the program stored within its internal memory upon startup, eliminating the need for an external operating system and ensuring faster and more reliable performance. As a highly compact and self-contained computing unit built on a single integrated circuit, the PIC microcontroller houses a processor core, dedicated memory, and programmable input and output peripherals, making it exceptionally well-suited for embedded applications such as this. The three infrared sensors



play a crucial role in classifying and categorizing obstacles within the surrounding environment by continuously scanning a defined area using an infrared beam. Whenever an object or barrier falls within the active scanning range of any of the IR sensors, the emitted infrared beam reflects off the surface of that obstacle and is promptly captured by the receiver unit embedded within the sensor, allowing the system to accurately detect the presence, position, and nature of the obstruction and relay the necessary warning to the user in real time.

### **3. PROPOSED SYSTEM AND FLOW OF SYSTEM**

#### **IC 7805**

Circuit may have fluctuations resulting in not providing fixed voltage outputs as per the requirement. A voltage regulator IC maintains the output voltage at a constant value as required. IC 7805 provides +5 volts regulated power supply which is needed for our device.

#### **Atmega328**

The Atmega328 is a low-power CMOS 8-bit microcontroller. It is based on enhanced RISC architecture. It is used in Arduino UNO board.

#### **Ultrasonic sensors**

Ultrasonic sensor is non-contact distance measurement device which works on the basic principle of emitting ultrasonic waves which is reflected back by the object calculating the distance based on time and speed. In this device we are using three ultrasonic sensors which are present on front, left and right side of the device. The supply voltage given is 5 volts at Global Current Consumption 15 mA. The Ultrasonic Frequency 40k Hz Maximal Range 200m Minimal Range 0.1 m.

#### **Panic Switch**

It is a button fitted on the blind stick device for emergency purpose which is connected with android app via Bluetooth communication.

#### **Navigation Switch**

This switch is being use to guide the blind person to reach their destination, with the help of android app connected via Bluetooth so that the person can start with its journey.

#### **Soil Moisture Detector**

Used to detect the moisture in the soil and gives voice command accordingly. It is used for the measurement of the volumetric water content in the soil by using the properties of the soil which are electrical resistance, dielectric constant and for proxy for the moisture content the interaction with neutrons.

#### **Arduino Uno**

The main hardware tool that we are using is Arduino Uno which is a microcontroller board based on the ATmega328. Arduino UNO comprises of the 14 digital input/output pins, 6 Analogue inputs, a USB connector for power supply and a reset button. It contains everything needed to support the microcontroller. It can be easily connected to a computer with a USB cable or battery to get started.

Its features are: -

Arduino boards are relatively inexpensive compared to other microcontroller platforms ranging from 8-bit microcontrollers to IoT applications.

1. The Arduino Software (IDE) is easy-to-use with simple programming environment.

2. Arduino Software (IDE) runs on Windows, Mac OSX, and Linux operating systems.
3. Arduino software is published as open-source tools, available for contribution by programmers worldwide.

### Android Device

Android Device will support the application for Navigation in this project by using the application of Google Maps which is interfaced with the device. Android Device works on Android Operating System which is a modified version of Linux Kernel and other open-source software.

### Bluetooth

Bluetooth is used to form network between personal computers. It is a wireless technology standard used for forming personal area network. The IEEE standard defined for Bluetooth is IEEE 802.15. The network formed works in defined range and is used for exchanging data over short distances using short wavelengths. For Smart Blind stick we use Bluetooth to interface the android device with the smart stick.

### Block diagram of Smart Blind Stick (Transmitter)

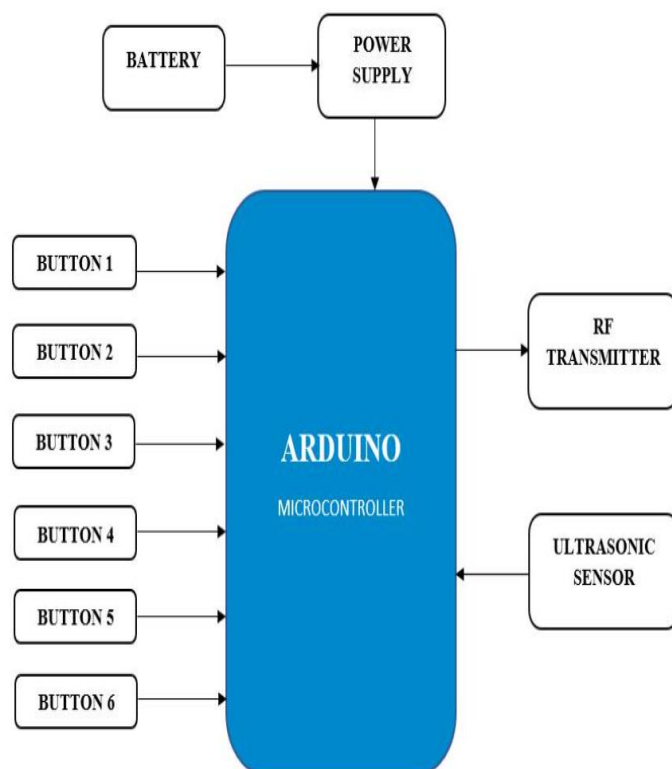

### Block diagram of Smart Blind Stick (Receiver)

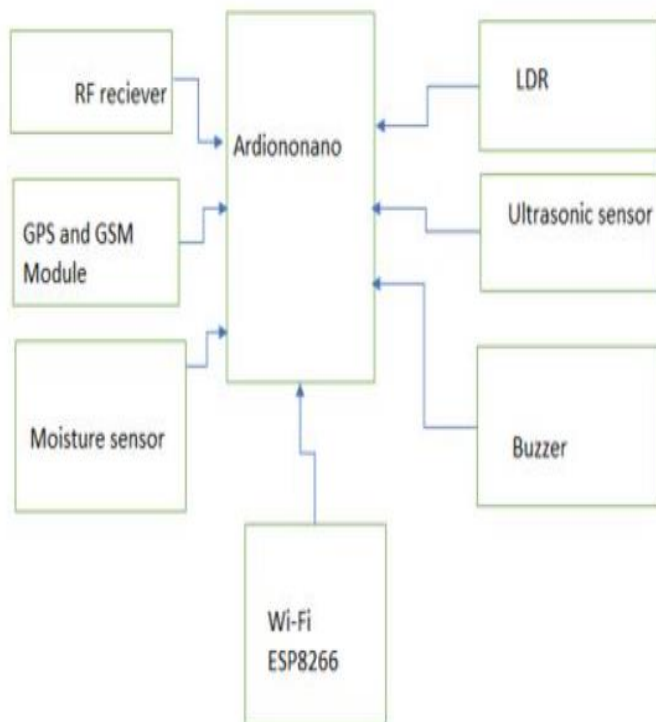

**Breadboard diagram of Smart Blind Stick**

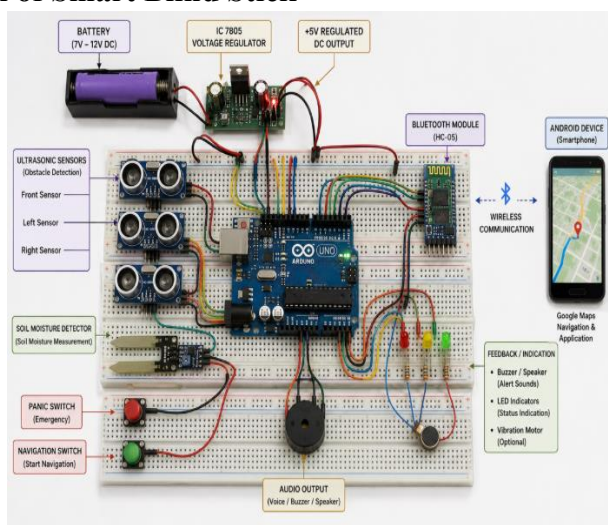

**4. SCOPE**

The Smart Blind stick is an innovative device designed for blind people for better navigation so that they can travel wherever they want. The device works on the principle of the same time global positioning system (GPS) which is linked with the voice stick for navigation so that person is aware of the current position and distance from the destination which will be informed to users through voice instructions given. A variety of future scope is available that can be used with Smart Blind Stick –

1. The smart blind stick can be connected to the user's Aadhar card so that the government can easily identify physically disabled people and provide them better support.



2. The smart blind stick can be connected to multiple smart devices like smartphones, smartwatches, smart home systems, and hospital monitoring systems through IoT technology.
3. By adding a GPS module and a small speaker or connecting it to earphones, the stick can speak out the location and directions to the user. This way blind people can travel alone without depending on others.
4. With GPS integration and real time connection to Google Maps or Bing Maps, the stick can guide the user by calculating both the shortest and safest path to their destination based on live traffic and road conditions.
5. A small camera can be attached to the stick that automatically starts recording the surroundings the moment any obstacle alarm or emergency alert is triggered.

#### **5. ADVANTAGES AND DISADVANTAGES**

1. Uses ultrasonic and infrared sensors to detect objects at various heights, alerting users through vibrations or beep sounds before any collision occurs.
2. Built-in GPS provides real-time turn-by-turn voice directions, helping visually impaired users travel safely to unknown locations without any external help.
3. A dedicated button instantly sends the user's live GPS location to pre-saved emergency contacts or nearby authorities during dangerous or critical situations.
4. Designed with durable yet lightweight materials, the stick is comfortable to hold for long hours without causing hand fatigue or physical strain.
5. Bluetooth and Wi-Fi connectivity allows the stick to sync with smartphones, hearing aids, or smartwatches, creating a fully integrated personal safety network.
6. Greater independence and personal safety directly contribute to reduced anxiety, improved self-confidence, and a stronger sense of dignity and freedom in daily life.

#### **6. RESULT**

The smart blind stick is given to a physically impaired person with a prior training.

1. The physically impaired person is taught the positions of the buttons present in the smart blind stick.
2. The owner should have an Android phone so that the installed application can be used.
3. On switching on the application, the mobile will be connected with the smart blind stick to Android through Bluetooth.
4. For the purpose of navigation, the person can press the navigation button and it will help them to reach their destination and will detect the obstacles present at left, right and front using ultrasonic sensors.
5. Whenever there is obstacle detection, there is a warning given to the blind person by voice command.
6. The blind stick also incorporates the feature of moisture detector order to detect mud and wet soil in the path.

#### **7. RESULT**

The Smart Blind Stick is a very helpful device made for blind and visually impaired people. It uses sensors like ultrasonic, infrared, and GPS to detect obstacles and alert the user through sound or vibration. This helps blind people walk safely without depending on others. This stick is lightweight, low-cost, and easy to use. It gives the user more confidence and independence in daily life. Compared to a normal white cane, the smart stick is much more



advanced because it can detect objects from a distance and warn the user before any accident happens.

The project shows how simple technology can solve real-life problems. In the future, this stick can be improved with AI-based features like voice assistance, fall detection, and real-time location sharing with family members. Overall, the Smart Blind Stick is a small device with a big impact. It can truly change the lives of visually impaired people by making their movement safer, easier, and more independent.

### 7. ACKNOWLEDGEMENT

The team members would like to acknowledge the efforts of our project guide, Dr. Monika Kapoor, her continuous efforts have propelled us to achieve our ideas. We would also like to thank all of our friends who have given valuable inputs in the pursuit of this project. We would also like to thank our college: Lakshmi Narain College of Technology, for providing us with the infrastructure to perform the project.

### REFERENCES

1. Amjed S. Al-Fahoum, Heba B. Al-Hmoud, and Ausaila A. Al-Fraihat. "A Smart Infrared Microcontroller-Based Blind Guidance System" Biomedical Systems and Informatics Engineering Department, Hijjawi Faculty for Engineering Technology, Yarmouk University, Irbid 21163, Jordan, 2011.
2. Loomis, J. M., Golledge, R. G., & Klatzky, R. L. (1998). "Navigation System for the Blind: Auditory Display Modes and Guidance." *Presence: Teleoperators and Virtual Environments*, MIT Press, USA. Vol. 7, No. 2, pp. 193–203.
3. Sharma, R., & Kumar, A. (2019). "Smart Blind Stick Using Ultrasonic Sensor and Arduino." *International Journal of Engineering Research & Technology (IJERT)*, Vol. 8, Issue 5.
4. N.Mahmud, R.K.Saha, R.B. Zafar, M.B.H. Bhuiyan, and S.S.Sarwar, "Vibration and Voice Operated Navigation System for Visually Impaired Person," In *Informatics, Electronics & Vision (ICIEV)*, International Conference on IEEE, pp. 1-5, 2014.
5. Manoj Kumar, Rohitverma, Mukesh Kumar, Shekhar Singh, Er. Thakurendra Singh. "Ultrasonic Based Smart Blind Stick for Visually Impaired Persons" *International Journal of Advanced Research in Electrical, Electronics and Instrumentation Engineering*, 2017.