



## **Data Transmission Using Li-Fi**

**<sup>1</sup>Mahak Singhai, <sup>2</sup>Karan Chhipa, <sup>3</sup>Kartikeya Dixit, <sup>4</sup>Manas Gupta, <sup>5</sup>Prof. Jatin Agarwal**  
<sup>1/2/3/4</sup>Student, <sup>5</sup>Guide

Dept. Of Electronics & Communication Engineering, LNCT Bhopal (M.P), India

<sup>1</sup>mahaksinghai925@gmail.com, <sup>2</sup>karanchhipa30@gmail.com, <sup>3</sup>kartikeya.dixit31@gmail.com,  
<sup>4</sup>guptamanas230@gmail.com

### **ABSTRACT**

The increasing reliance on traditional radio-frequency (RF) wireless communication technologies have introduced significant challenges, including spectrum congestion, electromagnetic interference, and growing security vulnerabilities. To address these limitations, Light Fidelity (Li-Fi) emerges as an innovative alternative that utilizes the vast visible light spectrum for high-speed, secure data transmission. This paper investigates the practical implementation of Visible Light Communication (VLC) by developing a microcontroller-based Li-Fi prototype capable of transmitting alphanumeric characters in real time. The system employs a high-brightness Light Emitting Diode (LED) as the transmitter, modulated via On-Off Keying (OOK), and a highly sensitive photodiode paired with a transimpedance amplifier at the receiver end to capture and decode the optical signals. Experimental testing confirms the successful reconstruction of transmitted data under controlled indoor conditions, highlighting the system's accuracy and energy efficiency. Furthermore, this study analyses the physical constraints of optical communication, such as ambient light interference and line-of-sight dependency, providing a foundational understanding of the technology and offering insights for the future deployment of Li-Fi in secure and interference-free environments.

**Keywords:** Arduino, data transmission, Li-Fi, photodiode, visible light communication

### **1.INTRODUCTION**

The rapid expansion of data-intensive devices has dramatically increased the demand for fast, secure, and interference-free wireless communication. Traditional radio frequency (RF) technologies like Wi-Fi and Bluetooth face growing limitations, including bandwidth constraints, electromagnetic interference, spectrum congestion, and security vulnerabilities. As global connectivity rises, RF systems alone are insufficient to meet expanding demands. To address these drawbacks, Light Fidelity (Li-Fi) has emerged as a promising alternative. Li-Fi is a Visible Light Communication (VLC) technology that transmits data by modulating the intensity of Light Emitting Diodes (LEDs) at speeds imperceptible to the human eye. At the receiver end, a photodiode detects these high-speed optical variations and converts them into electrical signals to decode the transmitted data.

Li-Fi offers extremely high data rates by utilizing the vast, untapped visible light spectrum. Because light cannot penetrate opaque barriers, Li-Fi inherently confines network access to specific areas, enhancing security without complex encryption. Furthermore, integrating Li-Fi



into existing LED lighting infrastructure provides a cost-effective and sustainable communication solution.

This paper details the implementation of a functional Li-Fi prototype using Arduino microcontrollers, a high-brightness LED transmitter, and a photodiode receiver. By transmitting alphanumeric characters in real time, the system demonstrates the feasibility of visible light for secure wireless communication. Finally, this study analyzes practical constraints—such as distance, alignment, and ambient light sensitivity—while highlighting Li-Fi's strong potential for future research and integration into modern networks.

### 2. LI-FI DATA TRANSMISSION MODEL

Light Fidelity (Li-Fi) is an emerging, powerful communication technology based on the fundamental principles of Visible Light Communication (VLC). Unlike traditional wireless systems such as Wi-Fi and Bluetooth that rely on radio waves, Li-Fi utilizes the visible spectrum of electromagnetic radiation to transmit data. It achieves this by rapidly modulating the light intensity of Light Emitting Diodes (LEDs). These light fluctuations occur at extremely high frequencies, rendering them completely imperceptible to the human eye. This unique mechanism allows the LEDs to perform a dual function: providing standard environmental illumination while simultaneously operating as a high-speed data transmission medium. At the receiving end, a photodiode or optical sensor captures these minute light variations and converts them back into electrical signals, which are then decoded to reconstruct the original digital information.

One of the most profound advantages of Li-Fi technology is the sheer capacity of its transmission medium. The visible light spectrum offers an enormous bandwidth capacity that is nearly 10,000 times greater than the heavily congested radio-frequency (RF) spectrum. This vast, unutilized bandwidth provides a compelling solution to the spectrum crunch currently faced by global wireless networks, offering significant potential for ultra-high-speed data exchange. By offloading data traffic to the visible spectrum, Li-Fi networks can effectively bypass the latency and congestion issues that plague heavily populated RF bands. Furthermore, Li-Fi provides inherent physical security and reliability benefits that RF systems lack. Because optical signals cannot penetrate solid objects or opaque walls, the communication channel is naturally confined to a specific, controlled physical area. This localized containment drastically reduces the risk of unauthorized signal interception, hacking, and data leakage without the immediate need for complex encryption protocols. Additionally, Li-Fi eliminates electromagnetic interference, making it an ideal technology for deployment in sensitive environments where RF signals are restricted or unsafe, such as hospitals, aircraft cabins, and chemical plants. Because LEDs are already widely adopted for general illumination across domestic and commercial spaces, integrating Li-Fi into this pre-existing infrastructure offers a highly cost-effective, sustainable, and energy-efficient solution for next-generation networking.

### 3. RESEARCH METHOD

To effectively address the technical challenges of visible light communication, this study adopts a systematic, multi-stage research methodology encompassing theoretical simulation, hardware implementation, and environmental testing. The primary objective is to evaluate



how high-speed, secure, and interference-free data transmission can be achieved using LED modulation and photodiode detection.

The methodology began with a comprehensive simulation phase to validate the theoretical design before physical assembly. By modeling the transmitter and receiver circuits in a controlled virtual environment, critical parameters such as LED switching speed, transimpedance amplifier (TIA) gain, and photodiode sensitivity were analyzed. This phase allowed for the observation of voltage waveforms under simulated ambient light conditions, ensuring that the predefined threshold for digital decoding (distinguishing between logical '1' and '0') remained stable across different noise levels.

Following successful simulation, the physical implementation phase focused on constructing a cost-effective, microcontroller-driven prototype. The transmitter was designed to handle data encoding and optical signal generation without causing visible LED flicker. Concurrently, the receiver was engineered to capture these minute optical variations, filter out environmental interference, and reconstruct the binary data stream. Finally, the system underwent rigorous empirical testing under varying line-of-sight distances and ambient lighting scenarios to evaluate performance metrics such as character transmission accuracy, response voltage levels, and bit error rates.

#### 4. CORE SYSTEM COMPONENTS

- **Transmitter Microcontroller (Arduino Nano):** The Arduino Nano serves as the intelligent core of the transmission unit. It is responsible for reading the input data, converting the characters into their corresponding 8-bit binary ASCII representations, and executing the modulation algorithm. It outputs a precise, high-frequency digital signal that drives the LED switching mechanism.
- **Optical Source (High-Brightness White LED):** Bridging the gap between digital electronics and optical communication, a high-power white LED acts as the transmission medium. It is capable of rapid intensity modulation—switching ON for a logical '1' and OFF for a logical '0' at speeds entirely imperceptible to the human eye. This allows the LED to perform its primary function of illuminating a space while simultaneously transmitting dense data streams.
- **Optical Detector (Photodiode):** At the receiving end, a reverse-biased photodiode functions as a highly sensitive light-to-electricity converter. When the modulated light pulses strike its surface, the photodiode generates corresponding, albeit minuscule, electrical current variations. Its rapid response time is critical for capturing high-frequency optical signals without data loss.
- **Signal Conditioning Circuitry (Resistors and Transimpedance Amplifier):** Because the current generated by the photodiode is too weak for the microcontroller to process directly, it is passed through a signal conditioning stage. A 220  $\Omega$  resistor protects the transmitting LED from excessive current, while a 10 k $\Omega$  resistor and a Transimpedance Amplifier (TIA) at the receiver convert the weak photocurrent into a measurable, amplified voltage. This stage also acts as a critical filter, removing low-frequency electrical noise introduced by ambient room lighting.
- **Receiver Microcontroller (Arduino Uno):** The Arduino Uno processes the amplified analog voltage signals from the conditioning circuit. It continuously samples the

incoming waveform, comparing it against a calibrated software threshold (e.g., 500 mV) to classify the bits accurately. Once an 8-bit sequence is captured, the Uno executes a demodulation algorithm to reconstruct the original digital character.

- **Output Display (16x2 LCD with I2C):** To provide real-time visual verification of the decoded data, a 16x2 alphanumeric Liquid Crystal Display is utilized. Interfaced via an I2C protocol using the MCP23008 expander chip to reduce wiring complexity, the display instantly outputs the reconstructed characters, confirming the successful transmission loop.

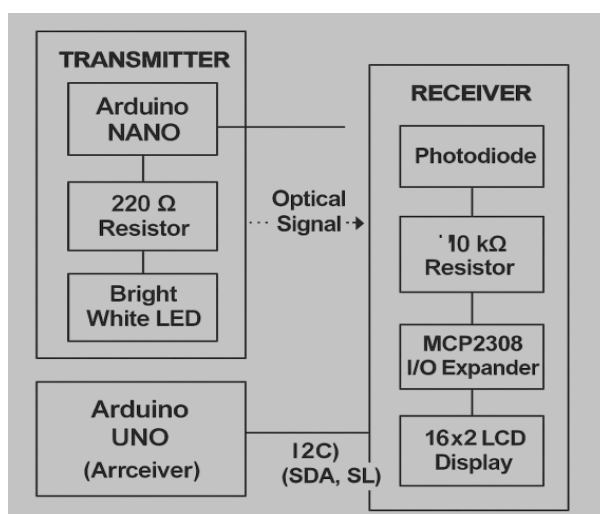

Fig. 1: Block diagram of Li-Fi data transmission system

## 5. WORKING MECHANISM

The operational mechanism of the Li-Fi communication system is a highly orchestrated process of converting digital data into light-based optical signals at the transmitter, followed by the precise reconstruction of that data at the receiver through optical sensing. This end-to-end communication cycle is governed by strict synchronization between the microcontroller algorithms and the analog electronic components.

1. **Data Encoding and Optical Modulation** The transmission phase initiates when the Arduino Nano receives a digital character intended for communication. The microcontroller's firmware processes this input by breaking the character down into its corresponding 8-bit binary ASCII representation. Utilizing On-Off Keying (OOK) modulation, the Arduino Nano drives the high-brightness white LED, instructing it to turn ON to represent a logical '1' and OFF to represent a logical '0'. Because LEDs are semiconductor light sources without mechanical delay, these transitions occur at exceptionally high frequencies. This rapid modulation ensures that the flickering remains entirely imperceptible to the human eye, allowing the LED to provide constant environmental illumination while simultaneously functioning as a high-speed data carrier.

2. **Signal Detection and Optical-to-Electrical Conversion** As the modulated light travels through the free-space optical channel, it strikes the sensitive surface of the reverse-biased photodiode at the receiver unit. The photodiode acts as a transducer, detecting the rapid variations in light intensity and generating a proportional electrical current. When the

transmitting LED is ON, the incident light increases, causing the photodiode to output a higher current; conversely, the current drops significantly when the LED is OFF.

3. **Signal Conditioning and Amplification** The electrical current generated by the photodiode is highly sensitive but exceedingly small—often in the microampere range—making it impossible for the receiving microcontroller to process directly. To resolve this, the raw current is fed into a signal conditioning circuit featuring a Transimpedance Amplifier (TIA) configuration. Utilizing specifically calibrated resistors (such as the 220  $\Omega$  and 10 k $\Omega$  resistors in the voltage divider network), the TIA boosts the weak photocurrent into a robust, measurable voltage. Crucially, this amplification stage also serves as an analog filter, smoothing out minor fluctuations and high-frequency noise introduced by environmental factors, such as light reflections or 50/60 Hz interference from ambient AC lighting.

4. **Demodulation and Data Reconstruction** The conditioned and amplified voltage signal is subsequently routed to the analog input pin (A0) of the receiver's Arduino Uno. The Uno's internal Analog-to-Digital Converter (ADC) continuously samples this incoming waveform. The microcontroller's demodulation algorithm compares each sampled value against a predefined, calibrated threshold (e.g., 500 mV). If the sampled voltage exceeds the threshold, the system registers a binary '1'; if it falls below, it registers a binary '0'. This precise decision-making process occurs in intervals of just a few milliseconds to ensure accurate bit capturing. Once a complete sequence of eight bits is collected, the Arduino Uno utilizes bitwise operations to reassemble the binary pattern back into the original ASCII character.

5. **Output and Verification** Immediately following reconstruction, the decoded character is transmitted via an I2C communication protocol (utilizing the MCP23008 expander) to the 16x2 LCD module. This provides immediate, real-time visual verification that the optical transmission loop was successful.

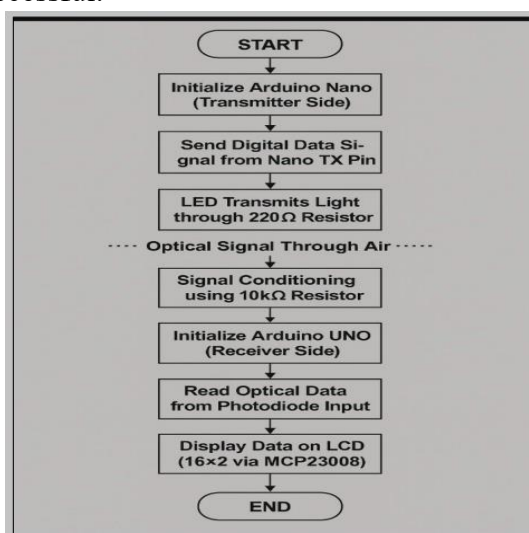

Fig. 2: Flow chart of Li-Fi data transmission system

## 6. SYSTEM PERFORMANCE AND RESULTS

With the deployment of the prototype in controlled indoor environments, optical data transmission demonstrated high reliability over short distances. Experimental results yielded a 100%-character transmission accuracy at a distance of 5 cm, and 98% accuracy at 10 cm.

Real-time feedback on the LCD confirmed successful synchronization between the transmitter's modulation and the receiver's sampling rate.

Voltage analysis further validated the system's thresholding logic. Under bright indoor lighting, the average amplified receiver voltage was 1.32 V for the ON state and 0.38 V for the OFF state, safely separated by the 0.50 V detection threshold.

Table I. Character Transmission Accuracy at Different Distances

Distance (cm)	Characters Sent	Characters Received Correctly	Accuracy (%)
5 cm	50	50	100%
10 cm	50	49	98%
20 cm	50	47	94%
30 cm	50	41	82%
40 cm	50	28	56%

Furthermore, the system's susceptibility to environmental noise was evaluated by calculating the Bit Error Rate (BER) across different lighting environments. As shown in Table II, the BER remains negligible under low to normal indoor lighting but increases sharply when exposed to strong ambient light sources, such as near a window.

Table II. Bit Error Rate (Ber) Under Varying Ambient Light Levels

Ambient Light Level	Total Bits Transmitted	Bit Errors	Bit Error Rate (%)
Low ambient light (night)	400	0	0%
Normal indoor lighting	400	3	0.75%
Bright indoor lighting	400	7	1.75%
Near window, strong light	400	15	3.75%

Voltage readings taken during real operation further validated the system's calibration. Even under bright indoor interference, the average receiver voltage for the ON state (1.32 V) remained significantly higher than the OFF state (0.38 V), safely separated by the predefined 0.50 V threshold.

### 7. CHALLENGES AND LIMITATIONS

While the prototype successfully demonstrated the practical feasibility of visible-light data transmission, empirical testing revealed several physical and environmental constraints inherent to optical communication:

- **Line-of-Sight Dependency:** Li-Fi requires a direct, unobstructed optical path between the LED and the photodiode. Any physical obstruction, such as hand movement or object placement, interrupts the communication link instantly.
- **Distance Constraints:** The effective transmission range is strictly limited by the brightness of the LED and the sensitivity of the photodiode. As the physical distance increases, the received signal weakens, leading to an elevated probability of incorrect threshold classification and higher bit error rates.
- **Ambient Light Interference:** Strong surrounding light sources—including direct sunlight, tube lights, and reflective surfaces—introduce significant optical noise. This ambient interference elevates the baseline voltage readings, requiring careful threshold adjustment or physical shielding of the sensor.



- **Alignment Sensitivity:** The angle of reception critically influences signal accuracy. Even minor misalignments between the transmitter and receiver reduce the effective light intensity captured by the photodiode, leading to occasional bit misinterpretations.

Despite these limitations, they are not fundamental flaws in the methodology but rather natural constraints of visible-light systems. These challenges point toward future enhancement opportunities, indicating that system robustness can be significantly improved through the integration of optical focusing lenses, adaptive thresholding algorithms, stronger LED sources, and more advanced modulation techniques.

### 8. CONCLUSION

The Li-Fi-based data transmission system developed in this study successfully demonstrates the practical feasibility of utilizing visible light as a medium for secure, wireless communication. By integrating an Arduino Nano transmitter, a high-intensity white LED, a photodiode detection unit, and an Arduino Uno receiver, the prototype effectively encoded, transmitted, and decoded alphanumeric characters in real time. The successful coordination of these hardware and software components validates the theoretical principles of Visible Light Communication (VLC). Furthermore, the implementation of a transimpedance amplifier proved critical in improving signal clarity, enabling the receiver to differentiate between logical 'ON' and 'OFF' states despite minor environmental fluctuations.

Empirical testing confirmed that the system performs exceptionally well under controlled indoor conditions, achieving high accuracy with negligible bit errors within an effective range of 20 to 25 cm. However, the study also highlights the inherent physical limitations of optical communication. The system's performance demonstrated a noticeable drop in accuracy when subjected to strong ambient light interference, increased transmission distances, and minor misalignments between the transmitter and receiver.

While these limitations restrict the current prototype's range, they highlight clear pathways for future enhancement, such as the implementation of adaptive thresholding algorithms, stronger LED sources, and advanced modulation schemes. Ultimately, this project provides a robust proof-of-concept for Li-Fi technology. It illustrates that even with accessible components, visible light can be harnessed to create a fast, secure, and energy-efficient data exchange network, offering a highly promising alternative to congested radio-frequency systems.

### REFERENCES

1. Arduino Documentation Team, "Arduino Nano and Uno Technical Specifications," Arduino Technical Reference, pp. 1-10, 2023.
2. Armstrong J., "OFDM for Optical Communications," Journal of Lightwave Technology, Vol. 27, No. 3, pp. 189-204, 2009, DOI: 10.1109/JLT.2008.2010061.
3. Harald Haas et al., "What is Li-Fi?" Journal of Lightwave Technology, Vol. 34, No. 6, pp. 1533-1544, 2016, DOI: 10.1109/JLT.2015.2510021.
4. Komine T. and Nakagawa M., "Fundamental Analysis for Visible-Light Communication System Using LED Lights," IEEE Transactions on Consumer Electronics, Vol. 50, No. 1, pp. 100-107, 2004, DOI: 10.1109/TCE.2004.1277847.



## **International Journal of Research and Technology (IJRT)**

**International Open-Access, Peer-Reviewed, Refereed, Online Journal**

**ISSN (Print): 2321-7510 | ISSN (Online): 2321-7529**

**| An ISO 9001:2015 Certified Journal |**

5. Pathak P. H., Feng X., Hu P., and Mohapatra P., "Visible Light Communication, Networking, and Sensing: A Survey, Potential and Challenges," IEEE Communications Surveys & Tutorials, Vol. 17, No. 4, pp. 2047-2077, 2015, DOI: 10.1109/COMST.2015.2476474.
6. Rajagopal S., Roberts R. D., and Lim S. K., "IEEE 802.15.7 Visible Light Communication Standard," IEEE Communications Magazine, Vol. 50, No. 3, pp. 72-82, 2012, DOI: 10.1109/MCOM.2012.6163585.
7. Wang Z. and Armstrong J., "LED-Based Optical Wireless Communications: Opportunities and Challenges," IEEE Communications Magazine, Vol. 50, No. 5, pp. 110-117, 2012, DOI: 10.1109/MCOM.2012.6194395.